

# Montageanleitung

Notice de montage

Assembly instruction

**GERMANIA**<sup>®</sup>  
the furniture factory

## Kleiderschrank 0128

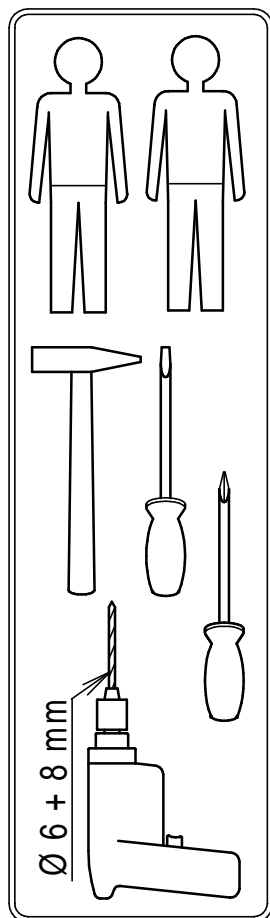
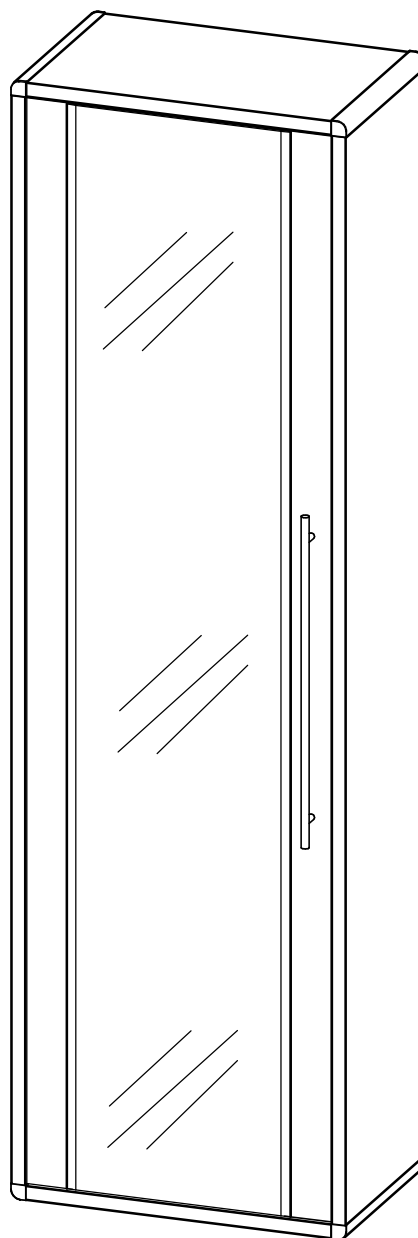

Bitte die Sicherheitshinweise auf der letzten Seite beachten!  
Please note: safety instructions on the last page!  
Prière de suivre les instructions de sécurité figurant sur la dernière page!

erstellt

geändert

geprüft

Datum: 04.07.07

Datum:

Datum:

Mod. 0128- **Teileliste** - liste de pièces - partlist

⓪ 2x

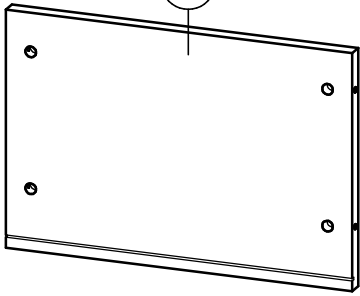

Ⓑ 1x

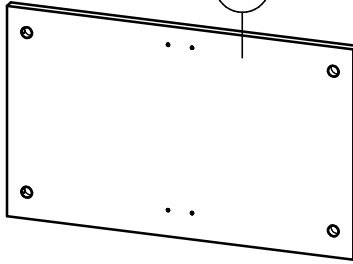

Ⓔ 1x

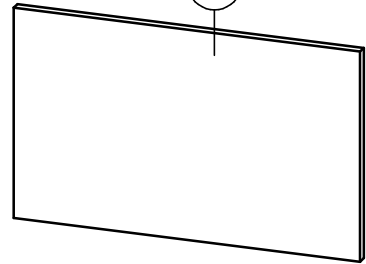

Ⓣ 1x

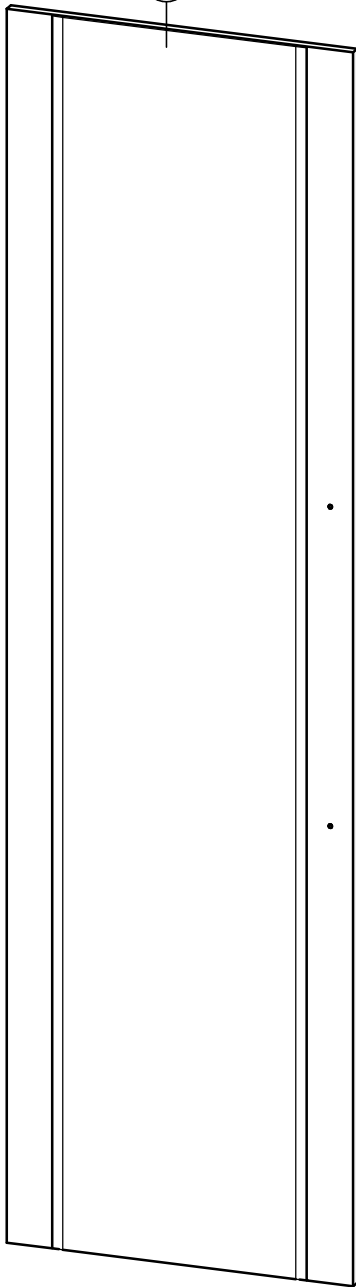

Ⓢ 2x

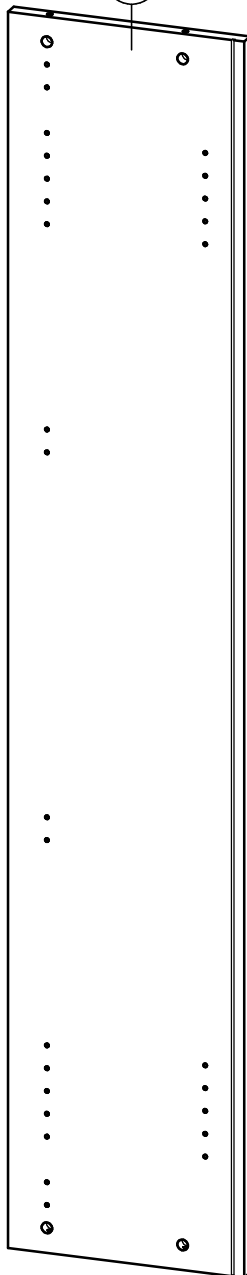



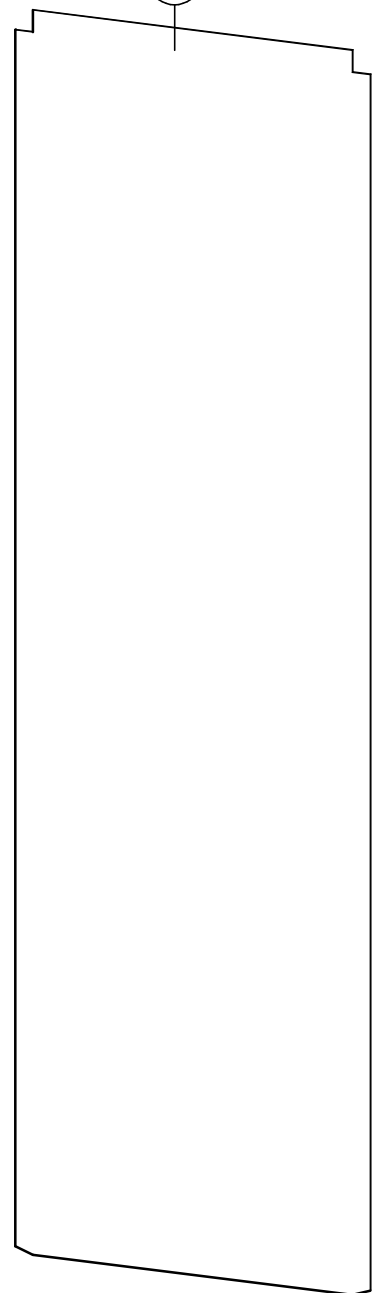







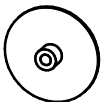
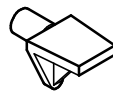

Ⓦ 1x

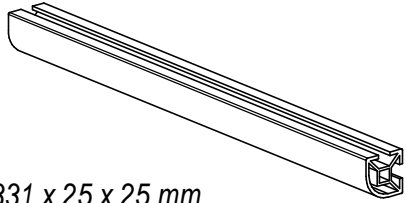
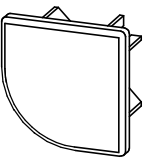

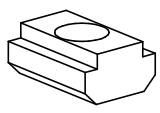
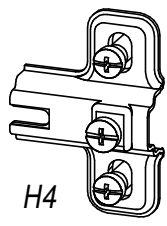
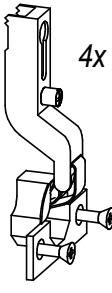
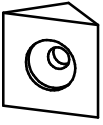
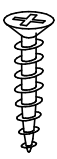
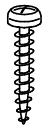
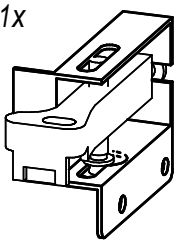
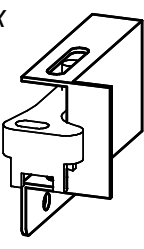
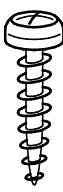
**2**

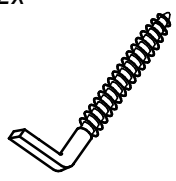
erstellt		geändert		geprüft	
Datum: 03.07.07		Datum:		Datum:	

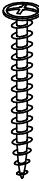
Mod. 0128 - **Teileliste** - liste de pièces - partlist

<p>1114 4x</p>  <p>24 mm</p>	<p>1116 20x</p>  <p>Ø15mm</p>	<p>1162 4x</p> 	<p>4162 4x</p> 	<p>4418 16x</p>  <p>Ø15</p>
<p>5544 4x</p>  <p>331 x 25 x 25 mm</p>	<p>5545 4x</p>  <p>3 x 25 x 25 mm</p>	<p>5546 16x</p>  <p>Minifix</p>	<p>5547 16x</p> 	
<p>4840 1x</p>  <p>H4</p>	<p>4x</p>  <p>4x</p>	<p>4095 4x</p> 	<p>1058 4x</p>  <p>Ø3x15 mm</p>	<p>1292 4x</p>  <p>Ø3,5x15 mm</p>
<p>5225 1x</p> 	<p>5226 1x</p> 	<p>1081 4x</p>  <p>Ø4x15</p>	<p>1111 2x</p>  <p>Ø8x40mm</p>	<p>1289 2x</p>  <p>Ø5,5x55mm</p>
<p>1187 1x</p>  <p>90x30x15 mm</p>	<p>1110 1x</p>  <p>Ø6x30 mm</p>	<p>1021 1x</p>  <p>Ø4,5x40 mm</p>	<p>1042 2x</p>  <p>Ø4x17 mm</p>	<p>1267 4x</p>  <p>Ø3x16</p>

# Mod. 0128 - Teileliste - liste de pièces - partlist

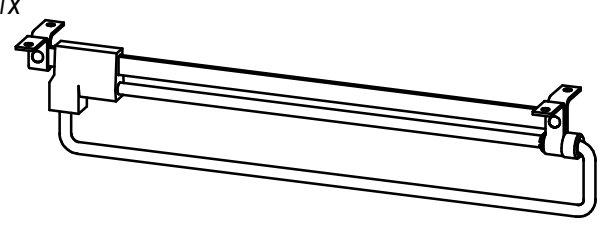
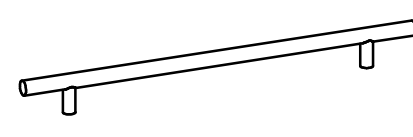
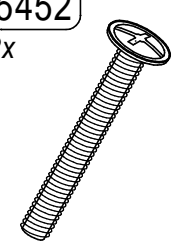
<p><b>5123</b> 1x</p>  <p>260 mm</p>	<p><b>5467</b> 1x</p>  <p>Teilung = 448 mm</p>	<p><b>5452</b> 2x</p>  <p>M4x40 mm</p>
---	--	---

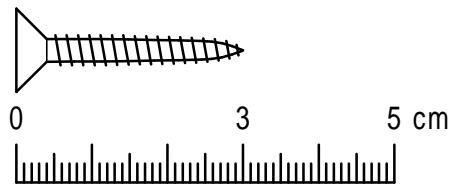

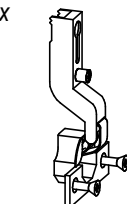
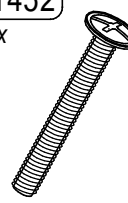
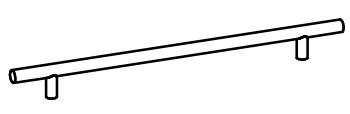

# Mod. 0128 - Montageschritte - ordre de montage - assembly instructions

**1.**

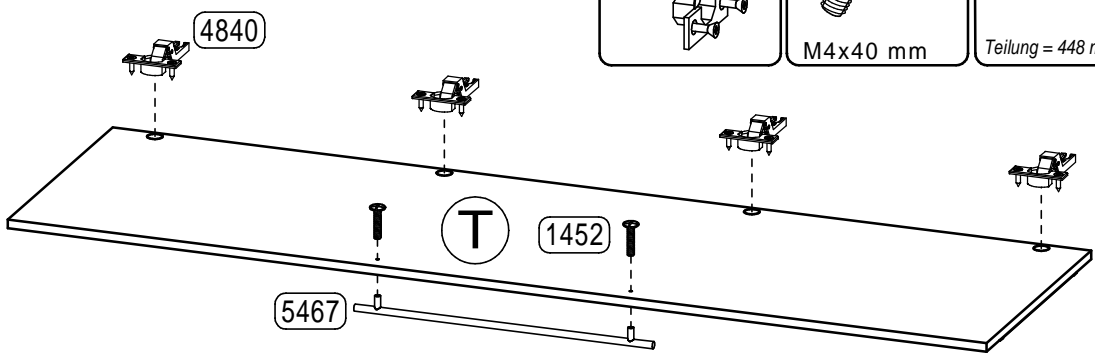
<p><b>4840</b> 4x</p> 	<p><b>1452</b> 2x</p>  <p>M4x40 mm</p>	<p><b>5467</b> 1x</p>  <p>Teilung = 448 mm</p>
--	---	---

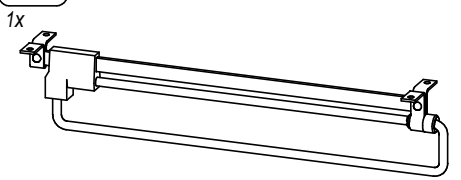

**2.**

<p><b>5123</b> 1x</p>  <p>260 mm</p>	<p><b>1292</b> 4x</p>  <p>Ø3,5x15 mm</p>
--	---

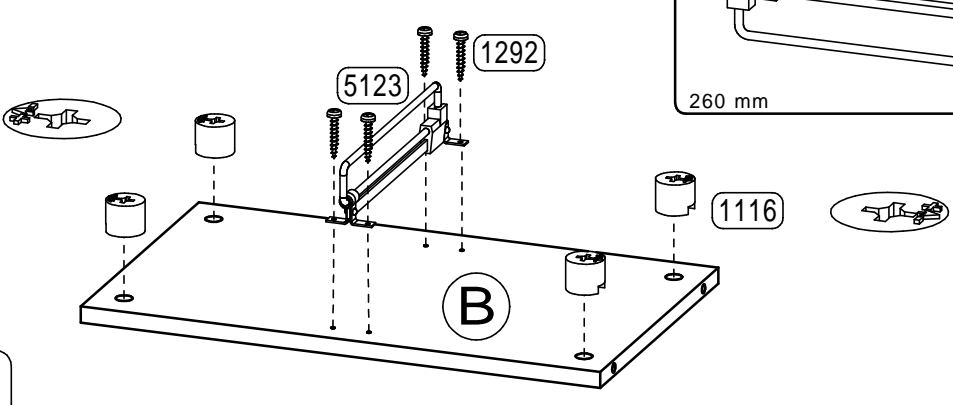

<p><b>1116</b> 4x</p> 
---

**4**

erstellt	geändert	geprüft
Datum: 03.07.07	Datum:	Datum:

Mod. 0128 - **Montageschritte** - ordre de montage - assembly instructions

**3.**

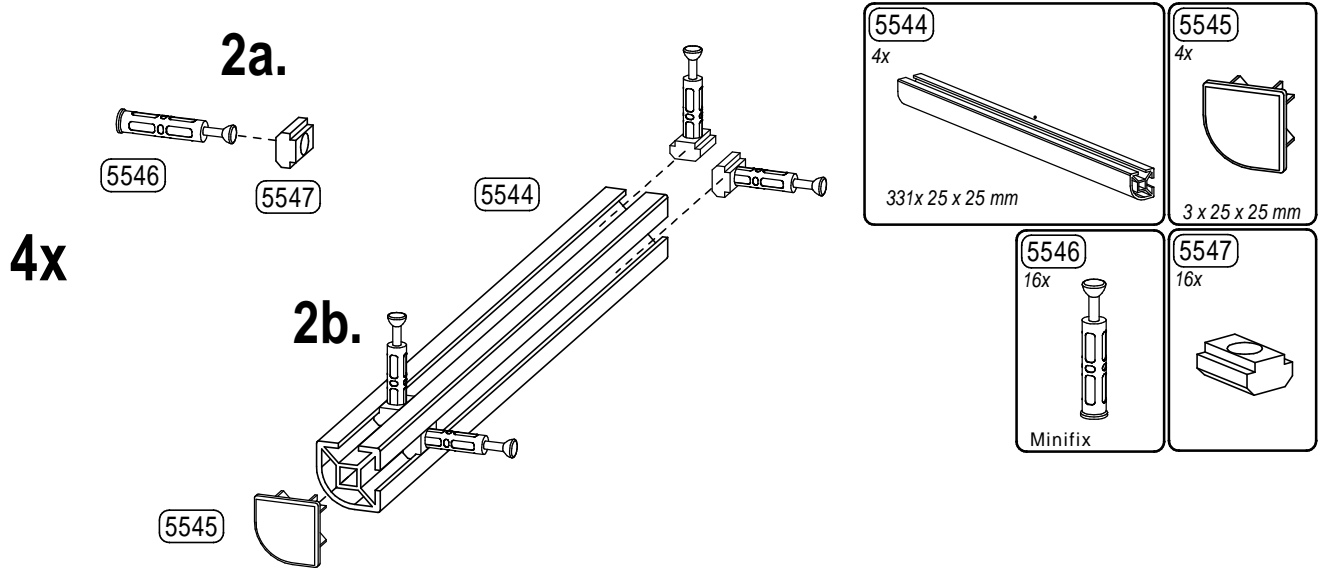

**4.**

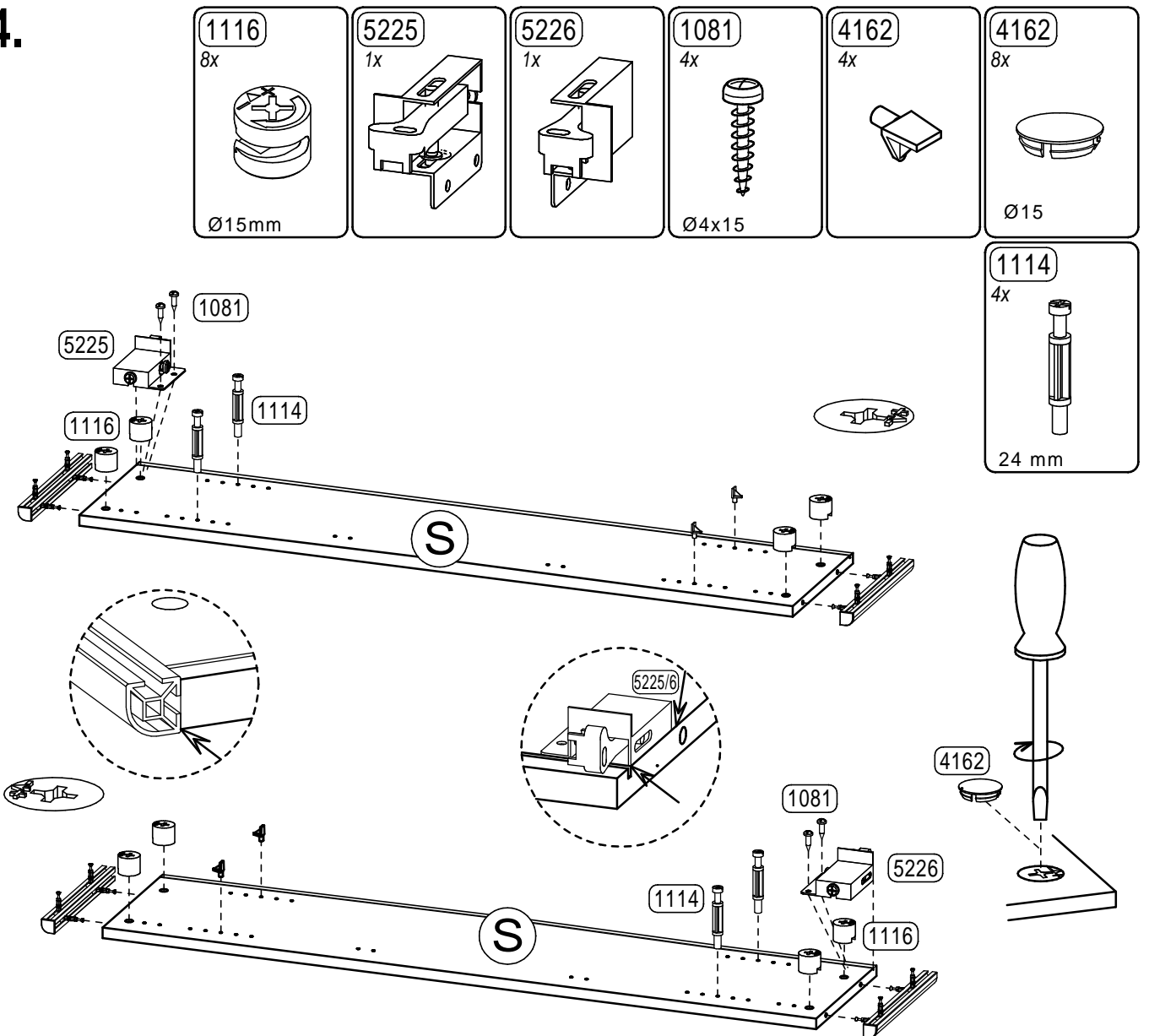

**5**

erstellt	geändert	geprüft
Datum: 03.07.07	Datum:	Datum:

5.

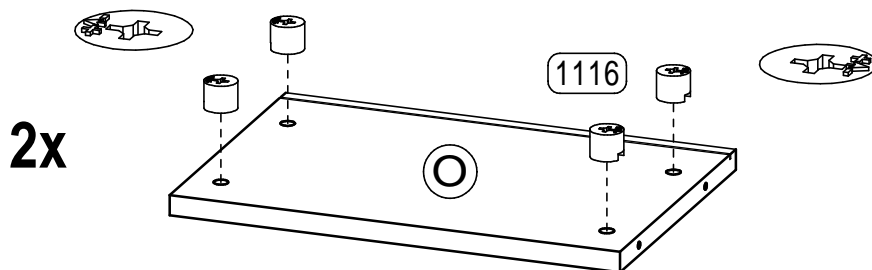

2x

1116

8x



Ø15mm

6.

4162

8x



Ø15

1162

4x

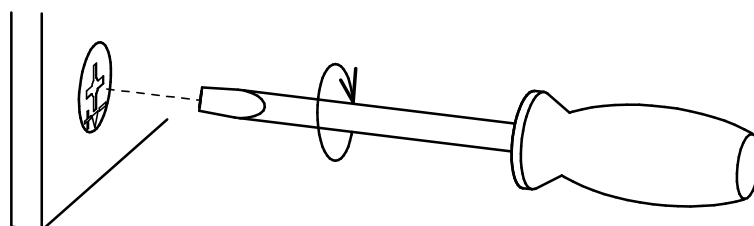
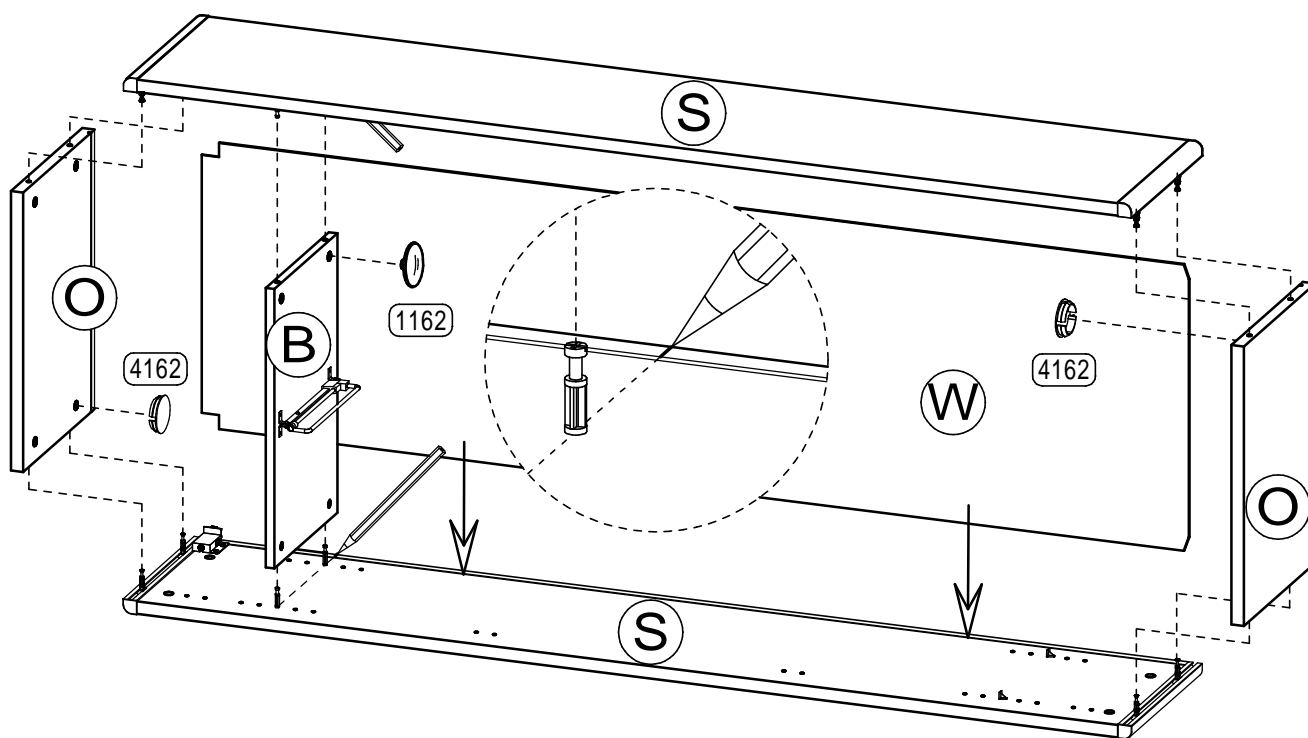

6

erstellt	geändert	geprüft
Datum: 03.07.07	Datum:	Datum:

**7.**

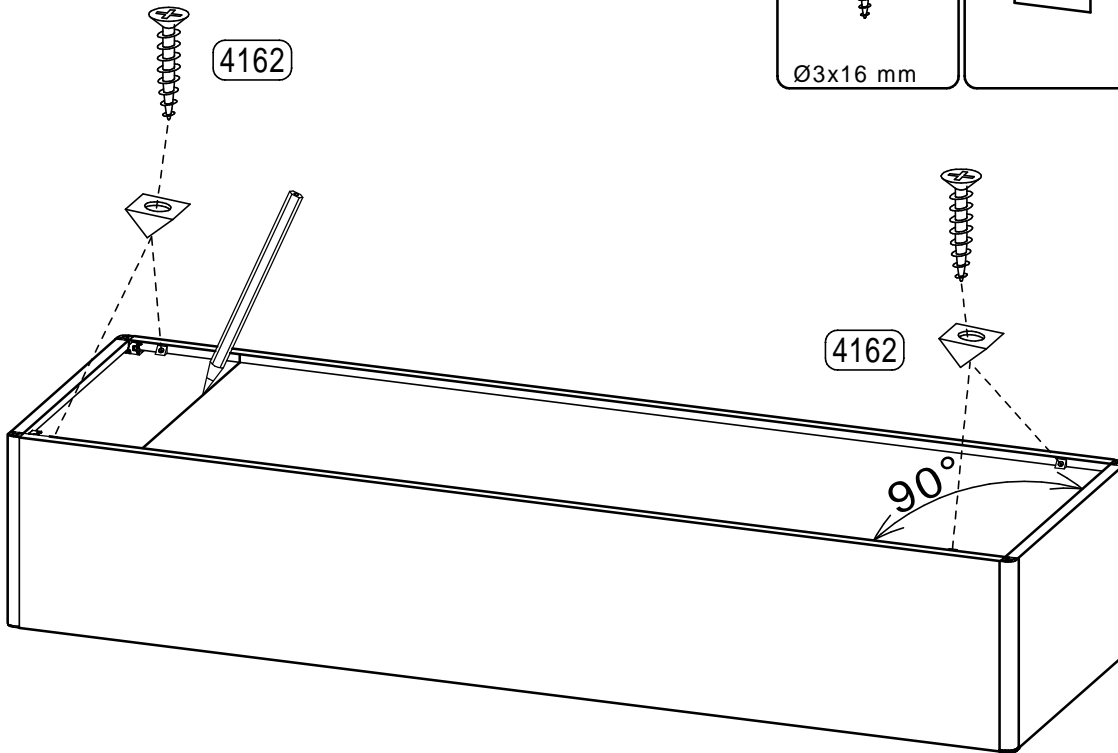
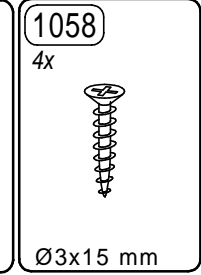
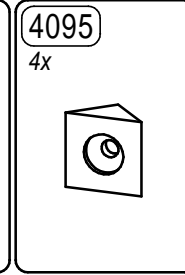
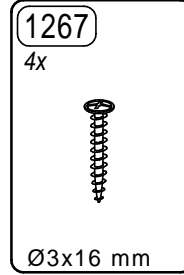

**8.**

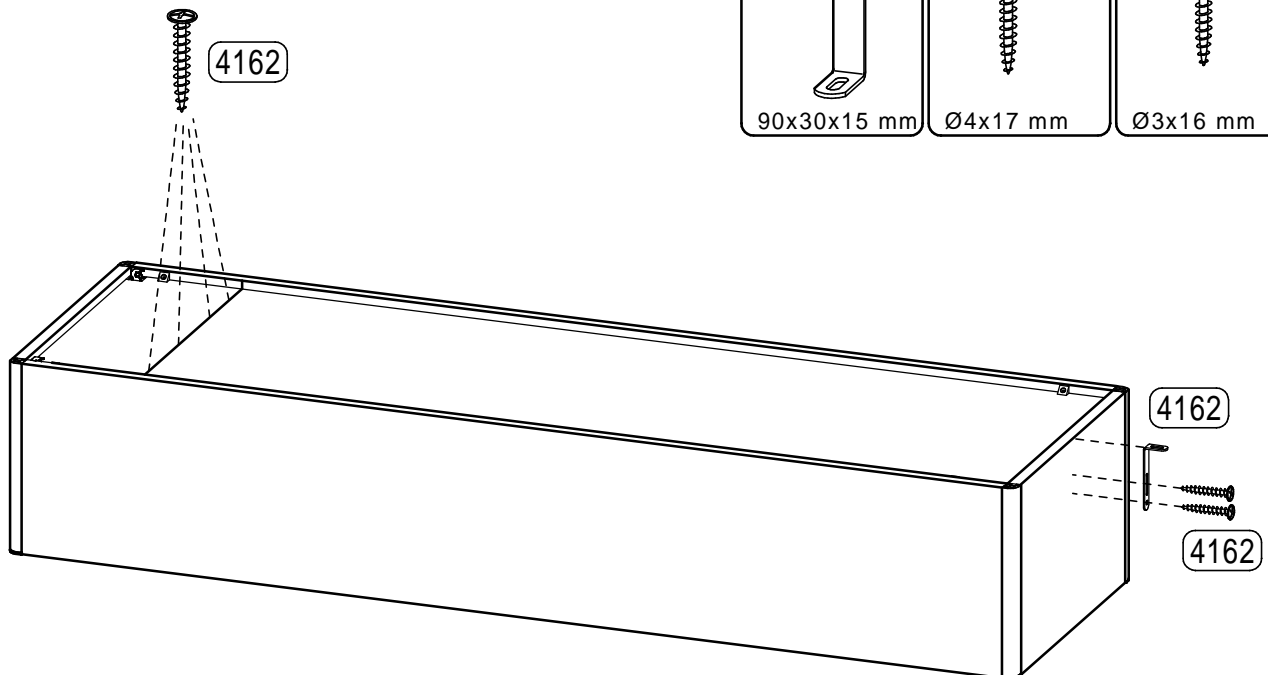
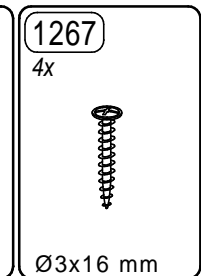
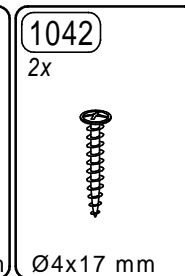
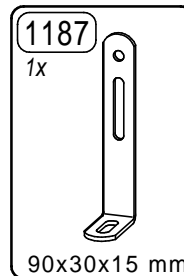

erstellt	geändert	geprüft
Datum: 03.07.07	Datum:	Datum:

9.

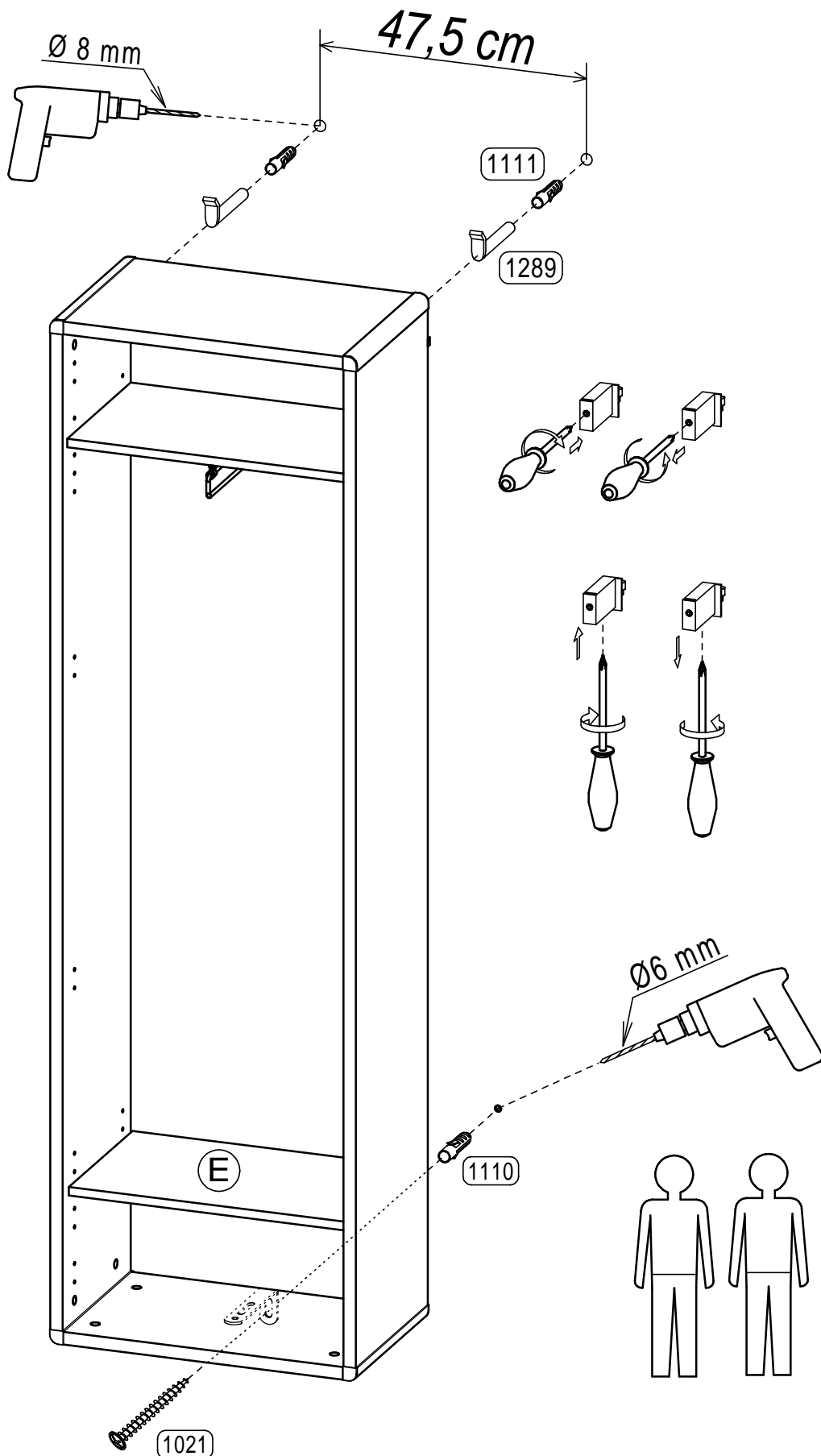

1110  
1x

Ø6x30 mm

1111  
2x

Ø8x40 mm

1021  
1x

Ø4,5x40 mm

1289  
2x

Ø5,5x55 mm

8

erstellt	geändert	geprüft
Datum: 03.07.07	Datum:	Datum:

# 10 L

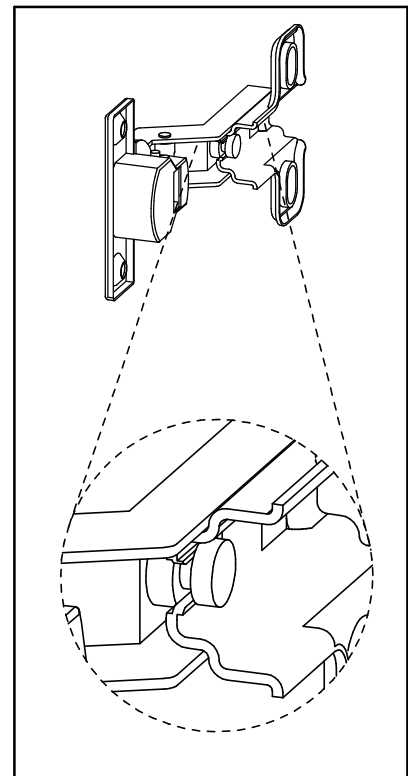
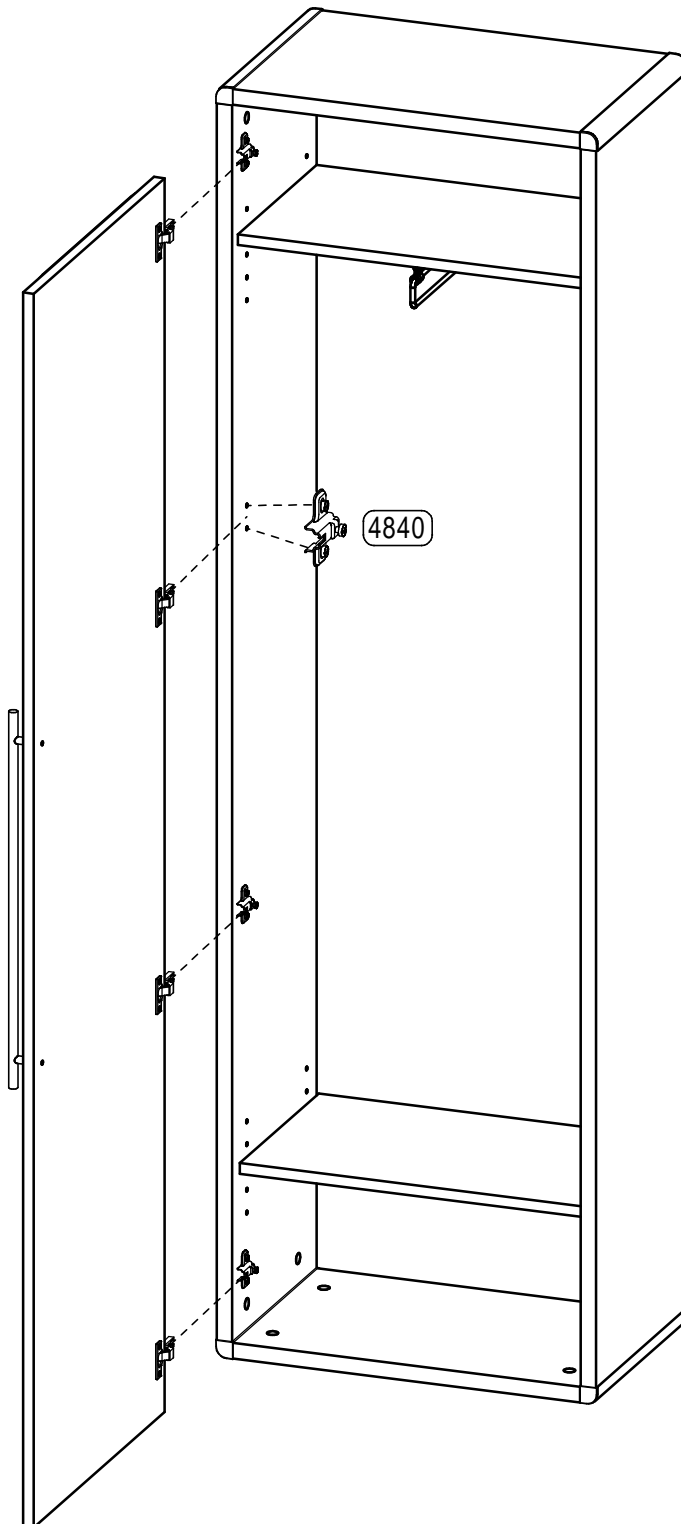
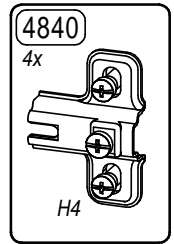

erstellt	geändert	geprüft
Datum: 03.07.07	Datum:	Datum:

# 10 R

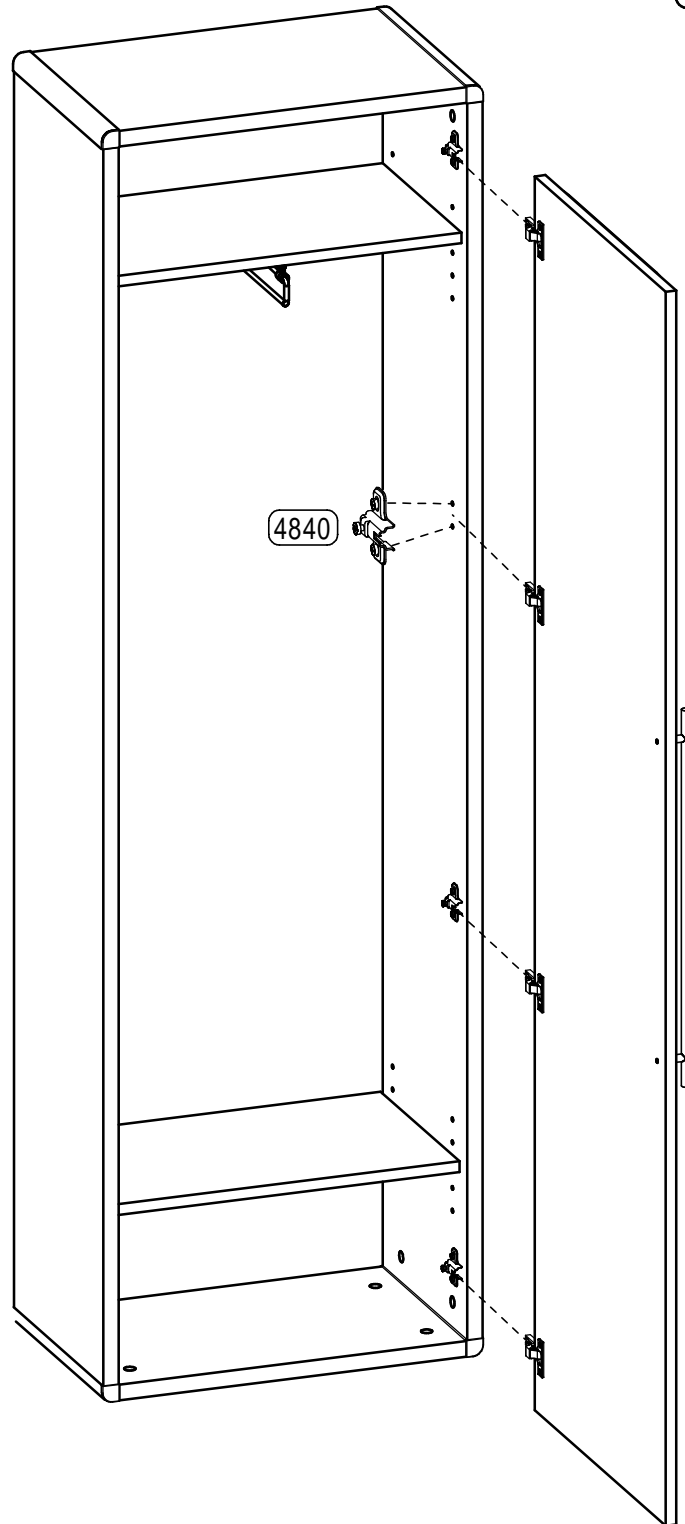
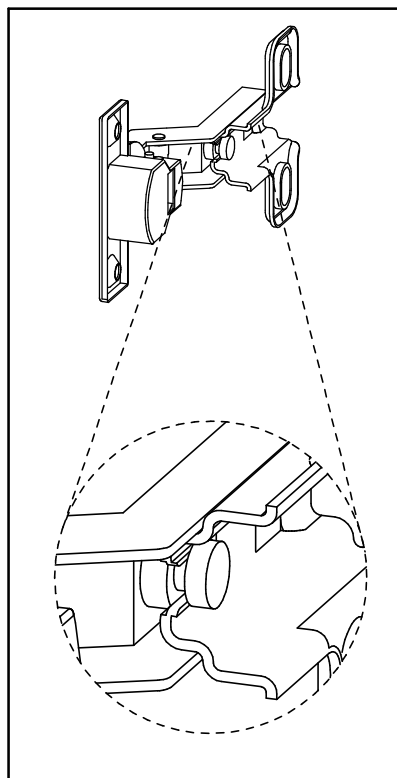
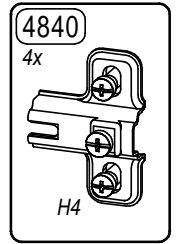

# 10

erstellt		geändert		geprüft	
Datum: 03.07.07		Datum:		Datum:	

# 11.

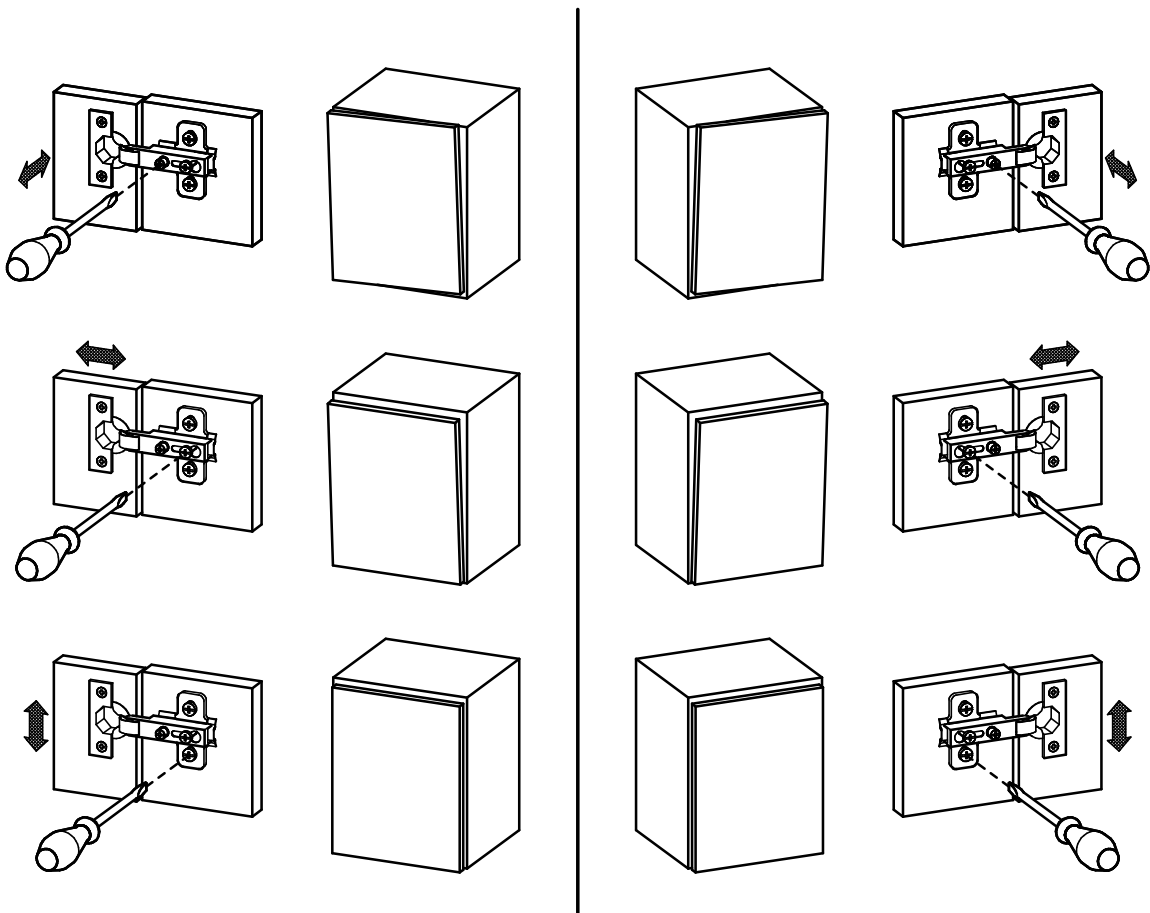

(nur für Deutschland - for germany only - seulement pour Allemagne)

Mod. Nr.: ..... Dekor-Nr.: .....

Möbelteile			
Teil	beschäd.*	fehlt *	Anzahl
Beispiel Z	X		1

Beschlagteile			
Teil	beschäd.*	fehlt *	Anzahl
Beispiel 9137		X	2

- Service - Postfach 1160

## Sicherheitshinweise Safety instructions Indications de sécurité

**GERMANIA**  
the furniture factory



1.) Montageanleitung aufmerksam durchlesen  
Please read assembly instruction carefully  
Prière de bien lire la notice de montage du début à la fin

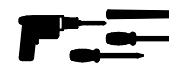

2.) Montage nach Montageanleitung durchführen  
Please follow the assembly instruction step by step  
Bien suivre le sens du montage indiqué sur la notice



3.) Montageanleitung aufbewahren  
Please save the assembly instruction  
Bien conserver la notice de montage



**ACHTUNG!** Beschlagbeutel und Beschlagteile von Säuglingen und Kindern fernhalten

**ATTENTION!** To avoid suffocation keep plastic bag away from children  
Contains small parts which may be a choking hazard

**ATTENTION!** Toutes les pièces détachées livrées dans le colis être mis hors de portée des bébés des et enfants

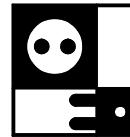

Netzanschluss (230V) nur von einem Fachmann ausführen lassen.  
Sanitäranschluss nur von einem Fachmann ausführen lassen.  
Mains connection (230V) has to be done by an expert.  
Sanitary installation has to be done by an expert.  
L'électricité (230V) uniquement à faire par un électricien.  
Installation sanitaire à faire par un spécialiste.

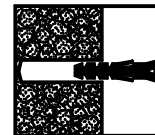

Beiliegendes Befestigungsmaterial eignet sich nur für Massivwände.  
Für andere Wände müssen Spezialdübel verwendet werden.  
Die Festigkeit ist zu Prüfen.

The attached fixing materials is only suitable for solid walls.  
For other Types of walls special dowels have to be used.  
The firmness have to be checked.

Le matériel defixation ci-joint est exclusivement prévu pour des murs pleins( une fixation spéciale est nécessaire pour cloisons placo,...).  
La fermeté est à examiner.



Beiliegende Wandbefestigungen dienen als Kippschutz, unbedingt anbringen!

The attached wall fixing is necessary to avoid tipping and must be fixed!

Les fixations prévues dans le colis préviennent contre le renversement du meuble. Il faut impérativement fixer le meuble au mur, afin d'éviter tout incident!

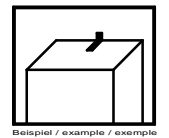

Für Schäden, die durch unsachgemäße Montage entstanden sind, übernehmen wir keine Haftung  
For the damages, which have originatet prom improper assembly, we take over no liability.  
Pour les dommages qui sont nés par le montage incorrect, nous ne prenons en charge aucune responsabilité.